



**Machine Mountable Electronic Level
with Bluetooth Technology
Model No. 40-6250**



Instruction Manual

Congratulations on your choice of this Machine Mountable Electronic Level with Bluetooth Technology. We suggest you read this instruction manual thoroughly before using the instrument. Save this instruction manual for future use. Additional copies are available at www.johnsonlevel.com.

Bluetooth is a trademark of Bluetooth SIG, Inc.

Table of Contents

- | | |
|---------------------------------|-----------------------------|
| 1. Kit Contents | 6. Using the Product |
| 2. Features and Functions | 7. Technical Specifications |
| 3. Safety Instructions | 8. Care and Handling |
| 4. Location of Parts/Components | 9. Product Warranty |
| 5. Operating Instructions | 10. Warranty Registration |

1. Kit Contents

<u>Model No. 40-6250</u>	<u>Qty.</u>
Sensor/Slaver (includes 3 AA Batteries)	1
Remote Control/Receiver (includes 3 AA Batteries)	1
DC 5V adapter	1
Remote cable & PC cable	1
Instruction Manual	1
Carrying case with strap	1

2. Features and Functions

- Use for new machinery installation and machinery relocation
- Read level horizontally in X and Y axis at a push of a button to within 0.01 degrees
- Operation range is ± 10 degrees of level
- Reads slope in %, mm/m, and in/ft
- Remote Control features large LCD screen that reads in X or Y axis
- Green backlit screen reads digitally and graphically
- Reads via cable outlet or wireless Bluetooth
- Bluetooth supported operating range 32'



3. Safety Instructions

Please read and understand all of the following instructions, prior to using this tool. Failure to do so, may void the warranty.

ATTENTION



IMPORTANT

- Read all instructions prior to operating this tool. Do not remove any labels from tool.
- Always turn the tool off when not in use or left unattended for a period of time.
- Remove the batteries when storing the tool for an extended time (more than 3 months) to avoid damage to the tool should the batteries deteriorate.
- Do not attempt to repair or disassemble the tool. If unqualified persons attempt to repair this tool, warranty will be void.
- Use only original Johnson® parts and accessories purchased from your Johnson® authorized dealer. Use of non-Johnson® parts and accessories will void warranty.



4. Location of Part/Components

Sensor/Slaver

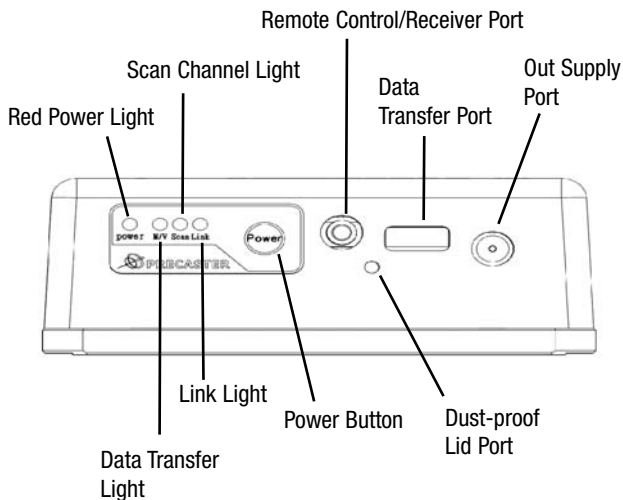



5. Operating Instructions

Sensor/Slaver

Battery Installation

The Sensor/Slaver requires 3 “AA” alkaline batteries to operate. Locate the battery door on bottom as shown in photo. Loosen screws, remove cover and install the batteries with correct polarity. Securely re-install battery door.



Power On and Off

Hold the power button for one second to power on the Sensor/Slaver. An audible beep and visual LED light will confirm the power is on.



Hold the power button for one second to power down the Sensor/Slaver. An audible beep and visual LED power light will confirm the power is off.

Remote Control/Receiver

Battery Installation

The Remote Control/Receiver requires 3 “AA” alkaline batteries to operate. Locate battery door, remove cover and install the batteries with correct polarity. Securely re-install battery door.





6. Using the Remote Control/Receiver

Remote Display

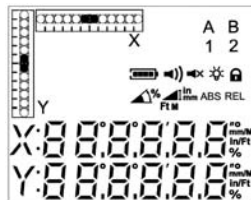

1. Power Button (POW)

- Hold for one second to power up Sensor/Slaver with beep.
- Hold for two seconds to turn off Remote Control/Receiver with beep.



2. Measure Button (MEAS)

- Push button to enable measuring and lock control pad with beep and visual LED is lit.
- Push button again to disable measuring and unlock control pad with beep and visual LED is off.



Note: All operation buttons will be non-responsive, except buttons 1, 2, & 7 - axis switch and backlight.

Begin measuring only after the link light of the Remote Control/Receiver and Sensor/Slaver are illuminated. If there is a delay in the illumination or the units are not connected, power down and then power up again.



3. Resolution Button (SEN/DEG)

Pushing this button will switch resolutions

- a. 0.002° - 0.01° - 0.1° - 1° - 0.002°
- b. Degree - Minute - Second



4. Function Button (mm, m; in/ft; CHN)

Pushing this button will switch functions

- a. Percentage of Slope (%)
- b. mm / M
- c. in / ft
- d. Channel Select (A-B-A)





5. Absolute, Relative and Degree Button (ABS/REL, WARN)

a. Absolute and Relative: switch between absolute and relative value

b. Degree Alert Set-Up

1. When degrees stop to X1 and Y1, press MEAS  to pause measure.
2. Press and hold this button until 3 beeps are heard to set alarm mode for 1 degree, LCD will display "1".



3. Then press MEAS  and move sensor to another desired X2 and Y2.
4. Pause MEAS  again and hold same button until 3 beeps are heard for set degree 2, LCD will display "2".
5. Remote Control/Receiver will beep when Sensor/Slaver is out of range (1 and 2).
6. To disable alert, press this button to enable 1 and 2.

Note: X & Y axis must be set independently. Preset minimum and maximum alarm prior to setting on surface to be leveled.



6. Lock and Quiet Button (LOCK/QUIET)

- a. Lock: to lock control pad
- b. Quiet: to disable beeper

Note: All operation buttons will be non-responsive, except buttons 1 & 6 - locking button.



7. Select Axis, Backlight and Calibration Button (X/Y BACKLED)

- a. Select Axis: press to switch display between X, Y, X n Y
- b. Backlight: hold for 2 seconds to turn on/off backlight
- c. Calibration: if this function is not working, please do not operate, it could cause level displacement. If the precision of the instrument is not correct and cannot be corrected, please send it back to our company for test and maintenance.



**Calibration Procedure:**

1. Put sensor on a flat plate ($\pm 3^\circ$)
2. Hold for 5 seconds to enable Calibration mode
3. If the LCD is flashing at 1, this means calibration step 1 is enabled
4. Press this button to enter step 2
5. If the LCD changes from 1 to 2, this means that calibration step 2 is ready.
6. Move sensor 180° , then press this button again (see below illustration)
7. The “2” will disappear to finish the calibration.

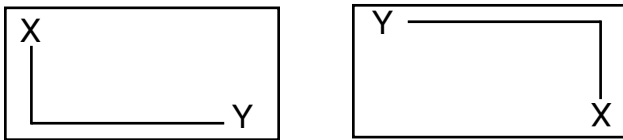

Rotate 180° Clockwise





7. Technical Specifications

Operation Range	-10° to +10°
Axis	X axis, Y axis
Resolution	0.002°, 0.01°, 0.1°, 1°
Repeatability	< 0.005° (2 σ)
Absolute Accuracy (25°C)	< 0.01° ($\pm 3^\circ$) < 0.04° ($\pm 10^\circ$)
Temperature Drifting	< 1" / °C (0°) < 1.5" / °C ($\pm 3^\circ$)
Response Time	< 2S
Operation Temperature	14°F to 122°F (-10°C to +50°C)
Storage Temperature	-4°F to 140° F (-20°C to +60°C)
Weight	300g (including 3 AA batteries)
Dimension	70mm x 24mm x 134mm (receiver)
Communication	Remote Control/Receiver: Bluetooth Output Cable Output Sensor/Slaver: Bluetooth Output Cable output, PC output
Power Supply	Remote Control/Receiver: 3 AA batteries Sensor/Slaver: DC 5V or 3 AA batteries
Range for Bluetooth	10m
LCD Display	40mm x 50mm Digital and Graph
Battery Life	Remote Control/Receiver: approx. 8 hours Sensor/Slaver: approx. 8 hours

RoHS Compliance, EU Instruction 91/338/EEC,
EU Instruction 94/62/EC, WEEE for EU/EG/EE, Chinese RoHS





8. Care and Handling

- Store instrument in a safe and dry climate controlled environment at standard room temperature.
- Do not throw, knock, or shake the instrument as this may damage the inner circuit boards.
- Remote Control/Receiver IS NOT water resistant. Should the instrument come into contact with water, be sure to wipe immediately with a dry towel and discontinue use until fully dry.
- Sensor/Slave IS NOT water resistant. Should the instrument come into contact with water, be sure to remove the batteries immediately in order to avoid a short circuit and replace them only after the instrument is completely dry. Be sure to wipe immediately with dry towel and discontinue use until fully dry.
- Avoid use outdoors. Rain and water contact with the power supply unit could result in electronic wire or instrument burn down.
- Store the instrument in a clean, dust free environment.
- Do not disassemble or modify the product, doing so will void your warranty.
- Do not use stimulative chemicals, or corrosive cleaning solvents to wash instrument.
- Do not in any way try to altar the instruments functionality or aesthetics.





9. Product Warranty

Johnson Level & Tool offers a one-year limited warranty on our Machine Mountable Electronic Level with Bluetooth Technology. You can obtain a copy of the limited warranty for a Johnson Level & Tool product by contacting Johnson Level & Tool's Customer Service Department, as provided below, or by visiting our web site at www.johnsonlevel.com. The limited warranty for each product contains various limitations and exclusions.

NOTE: The user is responsible for the proper use and care of the product. It is the responsibility of the user to verify the calibration of the instrument before each use.

For further assistance, or if you experience problems with this product that are not addressed in this instruction manual, please contact our Customer Service Dept.

In the U.S., contact Johnson Level & Tool's Customer Service Department at 888-9-LEVELS.

In Canada, contact Johnson Level & Tool's Customer Service Department at 800-346-6682.

10. Warranty Registration

Product Warranty Registration can be completed by calling 1-888-9-LEVELS. You will need to locate the serial number for your product that is located inside the battery compartment of the Remote Control/Receiver. **PLEASE NOTE THAT IN ADDITION TO ANY OTHER LIMITATIONS OR CONDITIONS OF JOHNSON LEVEL & TOOL'S LIMITED WARRANTY, JOHNSON LEVEL & TOOL MUST HAVE RECEIVED YOUR PROPERLY COMPLETED WARRANTY CARD AND PROOF OF PURCHASE WITHIN 30 DAYS OF YOUR PURCHASE OF THE PRODUCT OR ANY LIMITED WARRANTY THAT MAY APPLY SHALL NOT APPLY AND THERE SHALL BE NO WARRANTY.**

