

Rolling Stand with 12 Pivot Hangers

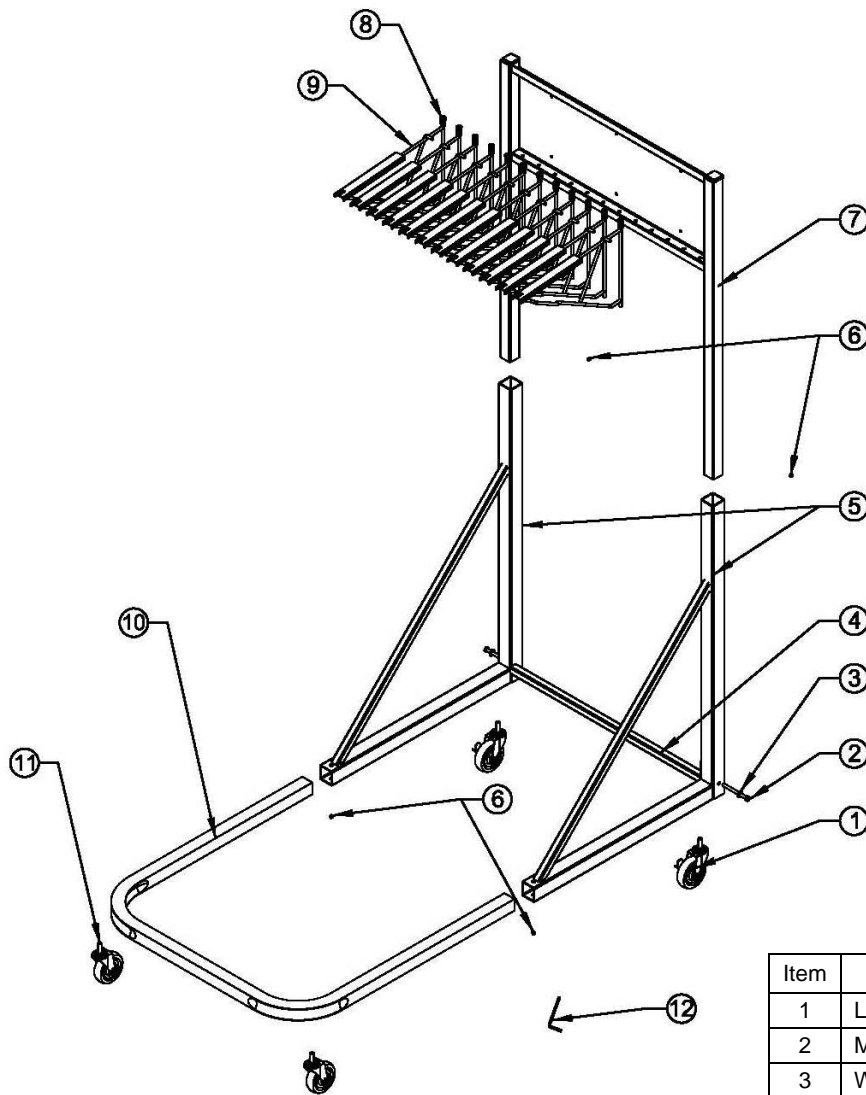

Item	Description	Qty
1	Locking caster assembly	2
2	M4X60 bolt	2
3	Washer	2
4	Spreader assembly	1
5	Side frame assembly	2
6	M6X8 set screw	4
7	Upper frame assembly	1
8	Spring	12
9	Hanger	12
10	Lower frame assembly	1
11	Caster assembly	2
12	Allen key	1

- 1) Slide lower frame assembly (10) into side frame assemblies (5).
- 2) Insert upper frame assembly (7) into side frame assemblies (5).
 [The side that installs 12 pivot hangers (9) must be faced forward.]
- 3) Install locking casters (1) in rear of unit and non locking casters (11) in front.
- 4) Insert 4 sets screws (6) into side frame assembly and adjust for height and depth.
- 5) Attach spreader assembly (4) to side frame assembly (5) using bolts (2) and washers (3) and fully tighten.
- 6) Insert hangers (9) with springs (8) into upper frame assembly (7).