



900CM

Includes Model Number 900CMB & 900CMP



104 S. 8th Ave. | Marshalltown, IA
Phone 800-888-0127 / 641-753-0127 | Fax 800-477-6341 / 641-753-6341
www.MARSHALLTOWN.com
WS2173

INTRODUCTION

This owner's manual provides the information needed to operate and maintain MARSHALLTOWN's 900CM Mixers. Carefully read and follow all safety and operating instructions in this manual. Also, be sure every operator of this mixer reads this manual before operating the mixer. The replacement of any part on this mixer by parts other than the manufacturer's authorized replacement parts may adversely affect the performance, durability, warranty or safety of the product.

Be sure safety precautions are observed. Read and follow all safety and operating instructions in this operator's manual.

The manufacturer reserves the right to make changes on, or add improvements to its product at any time without prior notice or obligation. The manufacturer reserves the right to decide, upon its sole discretion and at any time, to discontinue a product.

Information regarding operation and maintenance of the engine can be found in a separate engine manual supplied with this mixer if the mixer is supplied with an engine. The engine manual provides all the information required regarding engine adjustments, operation and maintenance. Should any questions arise concerning engine operation or service, contact the nearest engine repair facility or the engine manufacturer.

TABLE OF CONTENTS

Safety Precautions	3-4
Safety Decals	4
Warranty	5
Product Operation	6-7
Parts Breakdown	8-16

SAFETY PRECAUTIONS

This is the industry's safety alert symbol. This symbol calls attention to items or operations that could be dangerous. This symbol can be found throughout this manual and on safety decals on the mixer. Read these messages carefully.



CAUTION!

THE FOLLOWING PRECAUTIONS ARE SUGGESTED TO HELP PREVENT ACCIDENTS. A CAREFUL OPERATOR IS THE BEST OPERATOR. MOST ACCIDENTS CAN BE AVOIDED BY OBSERVING CERTAIN PRECAUTIONS. READ AND TAKE THE FOLLOWING PRECAUTIONS BEFORE OPERATING THIS EQUIPMENT TO HELP PREVENT ACCIDENTS. EQUIPMENT SHOULD BE OPERATED ONLY BY THOSE WHO ARE RESPONSIBLE AND INSTRUCTED TO DO SO.

1. Read all operating and maintenance instructions before operating or servicing mixer. Test run empty prior to actual use.
2. A mixer is only as safe as its operator. Give complete and undivided attention to the operation of the mixer.
3. Know how to stop the mixer and the engine instantly.
4. Always have all guards and safety devices attached and in place before operating mixer. Close engine housing during operation.
5. Keep inexperienced and unauthorized people away from the mixer at all times.
6. Never leave the mixer unattended while it is running.
7. Shut off engine before making any adjustments or putting hands or tools in the drum.

SAFETY PRECAUTIONS CONTINUED



Never reach into the drum or place tools into the drum while the mixer is running

8. Do not overfill the drum. Do not exceed the mixer's rated capacity.
9. Do not smoke while refueling the engine. Shut off the engine and allow it to cool before refueling. Do not spill fuel.
10. Block/chock mixer wheels when mixing.
11. Use safety chains while towing mixer.
12. Keep the mixer in good operating condition. Loose or damaged parts are dangerous.
13. Avoid loose clothing that could get caught in moving parts or on control levers.



Keep hands and feet away from moving parts

14. Do not add material to the drum while stopped. Start the drum before adding material.
15. Keep all warning, caution and safety instruction labels in good condition. Replace missing, damaged or illegible labels.

TOWING & SAFETY CHAINS

For transporting the mixer, slide the tow pole out as far as possible and insert the locking pin. Make sure drum is locked in position and engine housing is closed and secured; cross the safety chains under the tow pole and fasten them to the tow vehicle. (fig.1) When operating the mixer, slide the tow pole in and lock it in place.

NOTE! Safety chain length may need to be altered for proper connection to tow vehicle. Reposition the hooks, DO NOT cut chain.

Allow enough slack to permit proper vehicle turning while keeping chains snug enough to prevent tow pole from contacting the ground in case the hitch uncouples.

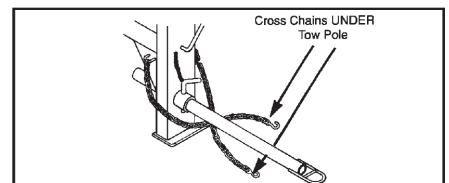

FIGURE 1

SAFETY DECALS (if applicable)

If your safety and operating decals are damaged, they can be replaced by contacting Customer Service

WS1066

SAFETY AND OPERATING INSTRUCTIONS

CAUTION!

1. Never reach into drum while it is rotating.
2. Stop engine or motor before cleaning or servicing.
3. Keep children and unauthorized people away from machine.
4. Never allow machine to run unattended.
5. Read owner's manual before operating or servicing this machine.

GENERAL PURPOSE CONCRETE

Proportions by volume:

- 1 part cement
- 2 1/2 parts sand
- 3 parts aggregate
- 7/8 parts water

With drum rotating, add water, aggregate, cement and sand in that order. Mix will be "mushy" not "soupy" for average moisture sand. Add or reduce water if sand is dry or wet.

CLEANING

1. With drum rotating, add water and aggregate.
2. Allow drum to turn for several minutes.
3. Dump water and aggregate.
4. Stop mixer by disconnecting motor or stopping engine.
5. Thoroughly clean with water before cement hardens.

LUBRICATION & SERVICE

1. Lubricate pinion shaft and drum shaft daily when in use.
2. Service engine or motor per manual supplied.

WS1066

MIXERS ONE-YEAR WARRANTY

This product is warranted to the original purchaser only, to be free of defects in material and workmanship under normal use, for one year from purchase date. Marshalltown Company shall without charge for parts and labor, repair or replace such parts which are found to be defective. All transportation charges for replacement parts must be borne by the purchaser.

For warranty service, the product must be delivered, with proof of purchase date, to the dealer of original purchase, or any factory authorized service dealer.

If difficulty is encountered in having warranty work performed, contact the factory Service Department.

All implied warranties, including those of merchantability and fitness for a particular purpose, are limited to one year from date of purchase by the original retail customer and to the extent permitted by law any and all implied warranties are excluded and disclaimed after the expiration of such period.

Some states do not allow limitations on how long an implied warranty lasts, or the exclusion or limitations of incidental or consequential damages, so the above limitations or exclusions may not apply to you. This warranty gives you specific legal rights, and you may also have other rights, which vary from state to state.

Exclusion from this warranty:

1. The following items are not covered under the Marshalltown Company one year warranty and are warranted by their respective manufacturer.
 - a) Engines, including starters, generators, alternators and gear reducers
 - b) Hydraulic components, including pumps, motors and valves
2. All consequential damages, including pickup and delivery of the unit, communication, mileage charges and/or rental of a replacement unit during repairs are not covered under this warranty, nor are any loss of income and/or other loss resulting from the failure of the product to function due to a warranty defect.
3. This warranty will not apply when the product becomes inoperative due to misuse, normal wear, neglect, improper maintenance, accident or freight damage, has not been operated and maintained in accordance with the instructions furnished in the Operator's Manual, or has been altered or modified without approval from the factory Service Department.
4. No parts or products are to be returned to the factory without prior written approval from the factory.

NOTICE: Record the model and serial numbers in the spaces provided.

Product Model Number: _____

Product Serial Number: _____

Engine/Motor Model Number: _____

Engine/Motor Code Number: _____

Purchase Date: _____

Dealer Purchased From: _____

Dealer Address: _____

Dealer Phone Number: _____

PRIOR TO START UP

1. Examine the mixer carefully to make sure there was no damage during shipment or since the last use. Report any damage immediately to the transportation company. Repair any damage before using the mixer.
2. Check the engine oil. Fill as required. Refer to the engine manual for oil specifications.
3. Fill the fuel tank with fresh, clean fuel. Refer to the engine manual for fuel specifications.
4. Grease all fittings as called out in the lubrication specifications.
5. Check hydraulic oil level in tank. The tank must be 75% full at minimum.
6. Replace hydraulic oil and filter every year or 300 hours of use. Refill with Lubsoil super hydraulic AW 32 or equivalent.
7. Check for free rotation of the mixer drum yoke by rotating the drum through one complete dump-charge-dump cycle. Make sure no foreign objects or tools are in the drum before starting the motor.
8. Start the motor and check for smooth operation of the drum, ring gear, and pinion.

LUBRICATION

Use lithium based grade 2 multi-purpose grease.

Yoke Bearing Hangers:

Yoke bearing hangers are located on the yoke ends and are equipped with grease fittings. These bearings should be greased weekly.

Wheel Bearings:

Grease wheel bearings once per year. Thoroughly remove old grease from bearings and spindle before repacking. Pack bearings $\frac{1}{2}$ to $\frac{2}{3}$ full to prevent overheating.

Drum Tilt Brake Bearing:

The brake bearing casting is located near the front of the mixer and should be greased weekly.

Handwheel Bearing:

The handwheel hub bearing is located on the front of the mixer, behind the handwheel. This bearing should be greased weekly.

WARNING: DO NOT GREASE BRAKE BAND OR OUTER BRAKING SURFACE OF TILT GEAR.

Engine/Motor:

Refer to the manufacturer's engine or motor operating instructions for all maintenance and lubrication requirements and instructions.

LUBRICATION FREQUENCY CHART

ITEM	FREQUENCY	LUBRICANT	PLACES
Yoke Bearing Casting	weekly	grease	2
Wheel Bearings	yearly	grease	2
Drum Tilt Brake Bearing Casting	weekly	grease	1
Handwheel Hub	weekly	grease	1
Drive Shaft	weekly	grease	1

STORAGE

For short term storage, clean the mixer and store in a dry place. If the mixer is not to be used for an extended period of time, service mixer completely and store it in a dry place.

1. Refer to motor/engine instructions for storage instructions.
2. Cover exposed metal surfaces with a thin coat of SAE 30 engine oil.
3. Lubricate per instructions under LUBRICATION section.

GETTING READY FOR MIXING

Lay out forms for your concrete floor, patio, driveway, sidewalk, etc. The quality of concrete is directly related to the quality of the cement paste. Calculate the proportions of your mix components (cement, sand and coarse aggregate) according to the job specifications.

LOADING THE MIXER

Start the mixer. Refer to motor/engine instructions. Start drum rotating clockwise by activating hydraulic valve lever. Pour about half of the water in the drum.

NOTE: The drum may leak slightly when first used. This will stop after a few batches. Add aggregate (gravel) first then cement second and sand last. Then add remaining water as needed.

MIXING INSTRUCTIONS

1. Start the drum rotating clockwise by activating hydraulic valve lever.
2. Add $\frac{1}{2}$ water.
3. Add cement and two shovelful of coarse aggregate. The coarse aggregate will break up any lumps in the cement.
4. Add remaining aggregate: crushed stone, pit-run gravel or sand.
5. Add remaining water as needed.
6. Mix batch for approximately one minute. Drum speed should be about 25 r.p.m. (NOTE: Mixing times may change.)

UNLOADING THE MIXER

Allow the entire mixture to mix for one full minute. Do not stop mixer from rotating.

Hold the tilt handle and unlock the stop lever. Dump concrete to either side by rotating handwheel in the direction required. (NOTE: Mixing times may change.)

CARE OF MIXER

It is important to keep the inside of the mixing drum free of hardened concrete. After discharging the last batch of concrete each day, add a pailful of water and two shovelfuls of gravel to the drum. This will scour the inside of the drum. Mix for about two minutes, discharge and rinse the drum with water. Never permit concrete to harden on either the inside or outside of drum.

TILT / LOCK MECHANISM

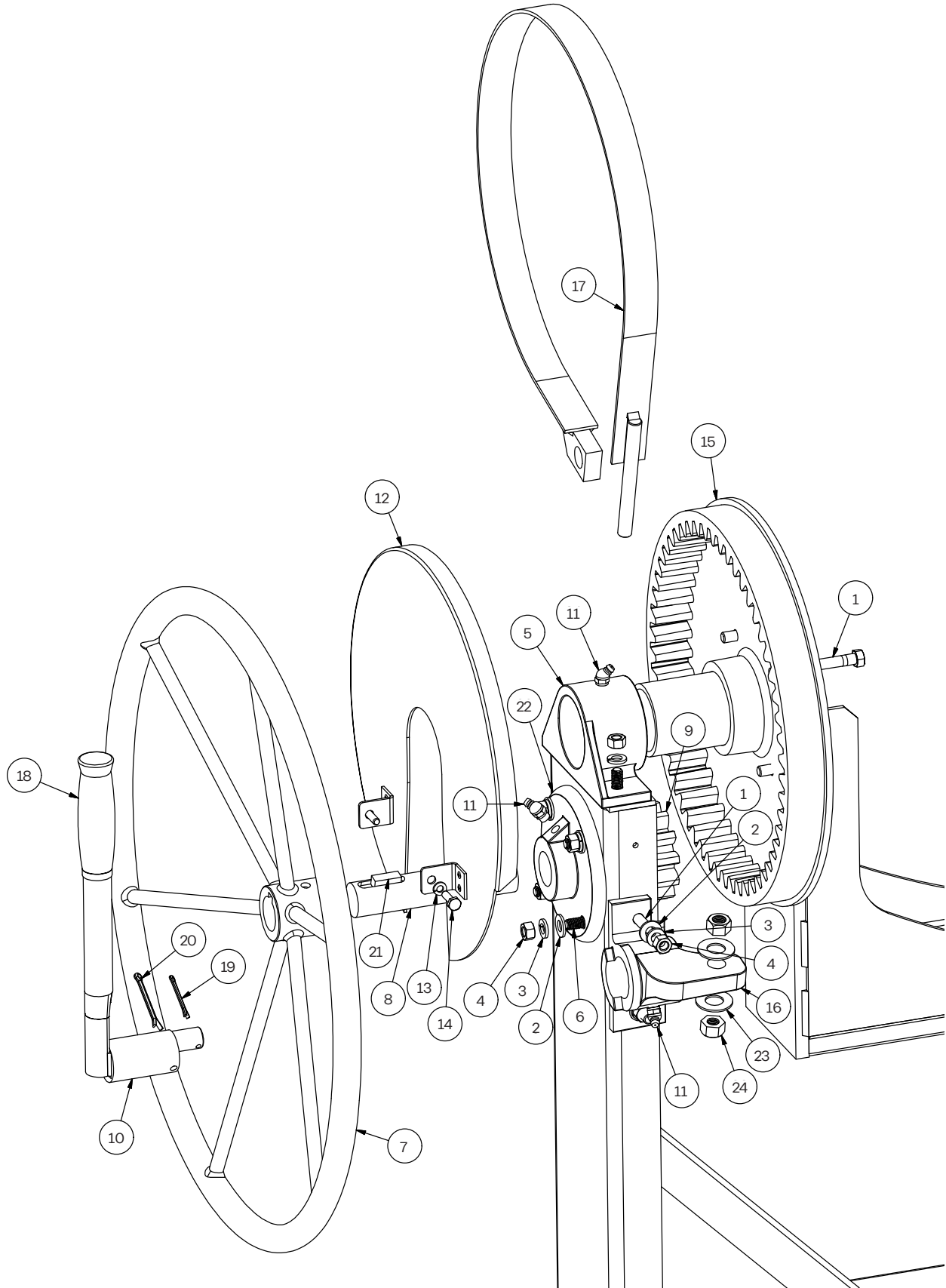

TILT / LOCK MECHANISM PARTS BREAKDOWN

REF #	NAME	PART #	QTY
1	HEX CAP SCREW 3/8"-16 X 1.5"	*	6
2	FLAT WASHER, 3/8"	*	6
3	LOCK WASHER, 3/8"	*	10
4	HEX NUT, 3/8"-16	*	10
5	YOKE BEARING, 600CM	MIX19027	1
6	CARRIAGE BOLT 3/8"-16 X 1 1/4"	*	6
7	HANDWHEEL ASSM, 900CM	R0667	1
8	TILT PINION SHAFT, 600CM	MIX19061	1
9	TILT PINION-600CM	MIX19098	1
10	LEVER, BRAKE ASSM, 600CM	MIX19087	1
11	GREASE FITTING, 1/8"	*	4
12	TILT GEAR COVER-600CM	MIX29357	1
13	LOCK WASHER, 1/4"	*	2
14	HEX CAP SCREW 1/4"-20 X 3/4"	*	2
15	GEAR, INTERNAL TILT, 600CM	MIX19102	1
16	BRAKE BEARING-600CM	MIX19030	1
17	BRAKE BAND ASSY	MIX19119	1
18	GRIP	*	1
19	COTTER PIN 1/8" X 1 1/2"	*	1
20	COTTER PIN	*	1
21	KEY STOCK 3/8 SQ X 1"	*	2
22	HANDWHEEL BRG 600CM	MIX19029	1
23	FLAT WASHER, 1/2"	*	2
24	HEX NUT, 1/2" - 13	*	2

* Common hardware, can be purchased locally.

TILT / LOCK MECHANISM REPLACEMENT KITS ON NEXT PAGE...

TILT / LOCK MECHANISM REPLACEMENT KITS

900CM TILT/LOCK GEAR COVER EDI# 27789 INCLUDES:

REF #	NAME	QTY
12	TILT GEAR COVER - 600CM	1
13	LOCK WASHER, 1/4"	2
14	HEX CAP SCREW, 1/4"-20 X 3/4"	2

900CM TILT/LOCK LOCK MECHANISM EDI# 27790 INCLUDES:

REF #	NAME	QTY
18	GRIP	1
10	LEVER, BRAKE ASSM, 600CM	1
19	COTTER PIN 1/8" X 1 1/2"	1
20	COTTER PIN	1
11	GREASE FITTING, 1/8"	1
16	BRAKE BEARING-600CM	1
1	HEX CAP SCREW 3/8"-16 X 1 1/2"	1
2	FLAT WASHER, 3/8"	1
3	LOCK WASHER, 3/8"	1
4	HEX NUT, 3/8"-16	1
17	BRAKE BAND ASSY	1
23	FLAT WASHER-1/2"	2
24	HEX NUT, 1/2"-13	2

900CM TILT/LOCK GEARS SHAFT PILLOW BLOCK EDI# 27791 INCLUDES:

REF #	NAME	QTY
15	GEAR, INTERNAL TILT, 600CM	1
9	TILT PINION - 600CM	1
1	HEX CAP SCREW 3/8"-16 X 1 1/2"	4
21	KEY STOCK, 3/8" SQ X 1"	2
8	TILT PINION SHAFT, 600CM	1
6	CARRIAGE BOLT 3/8"-16 X 1 1/4"	6
2	FLAT WASHER, 3/8"	6
3	LOCK WASHER, 3/8"	4
4	HEX NUT, 3/8"-16	6
11	GREASE FITTING, 1/8"	2
5	YOKE BEARING, 600CM	1
7	HANDWHEEL BRG 600CM	1

DRUM PADDLE INSTALLATION

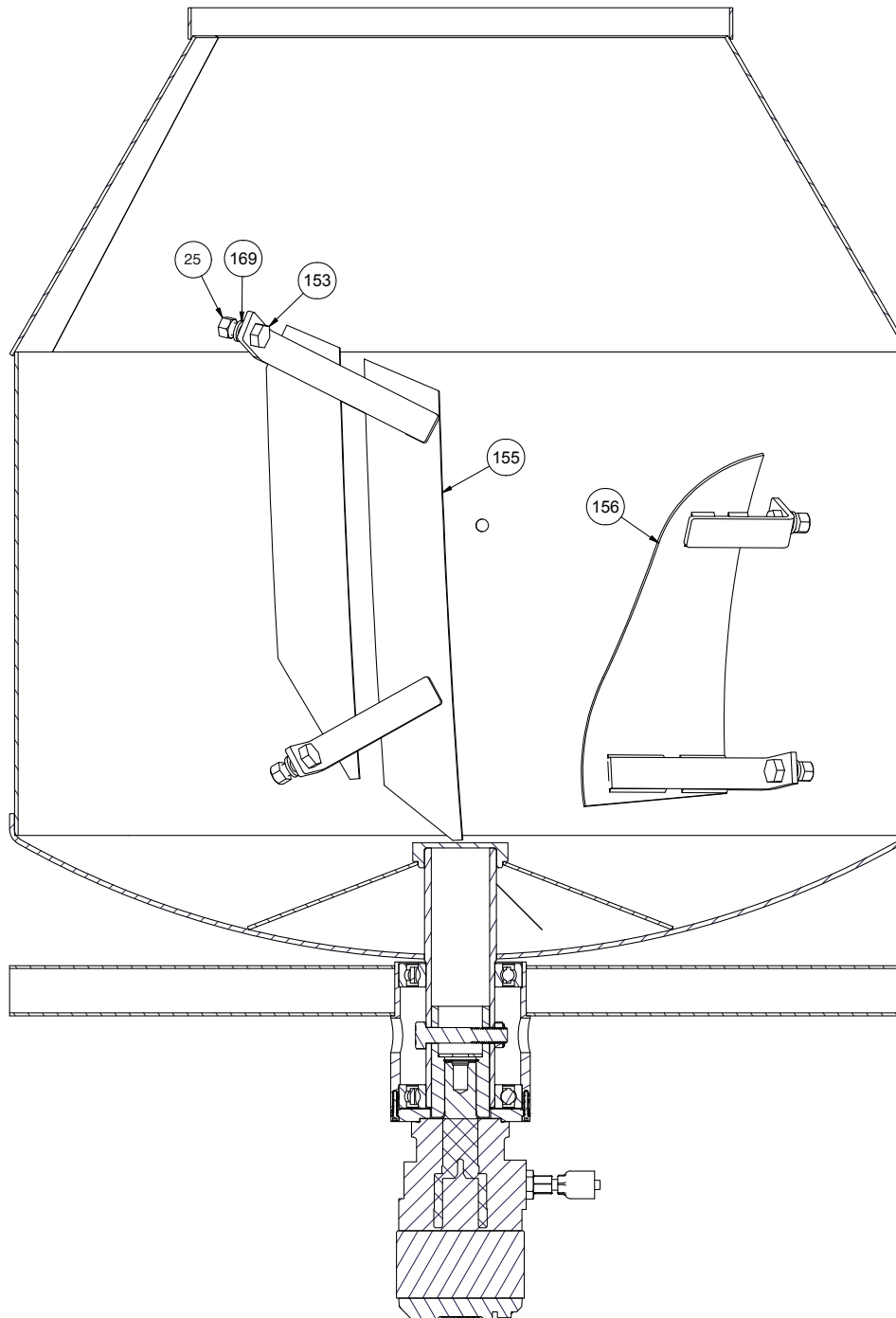

DRUM PADDLE PARTS BREAKDOWN:

REF #	NAME	PART #	QTY
25	NUT 1/2-13	*	8
169	LOCK WASHER, 1/2"	*	8
153	HCS 1/2-13 X 1.25" LONG	*	8
155	BLADE ASSM, 600CM TOP -PC-BLUE	R0484	2
156	BLADE ASSM, 600CM BOTTOM-PC-BLUE	R0483	2

* Common hardware, can be purchased locally.

STEEL DRUM, YOKE, AND DRUM SHAFT ASSEMBLY

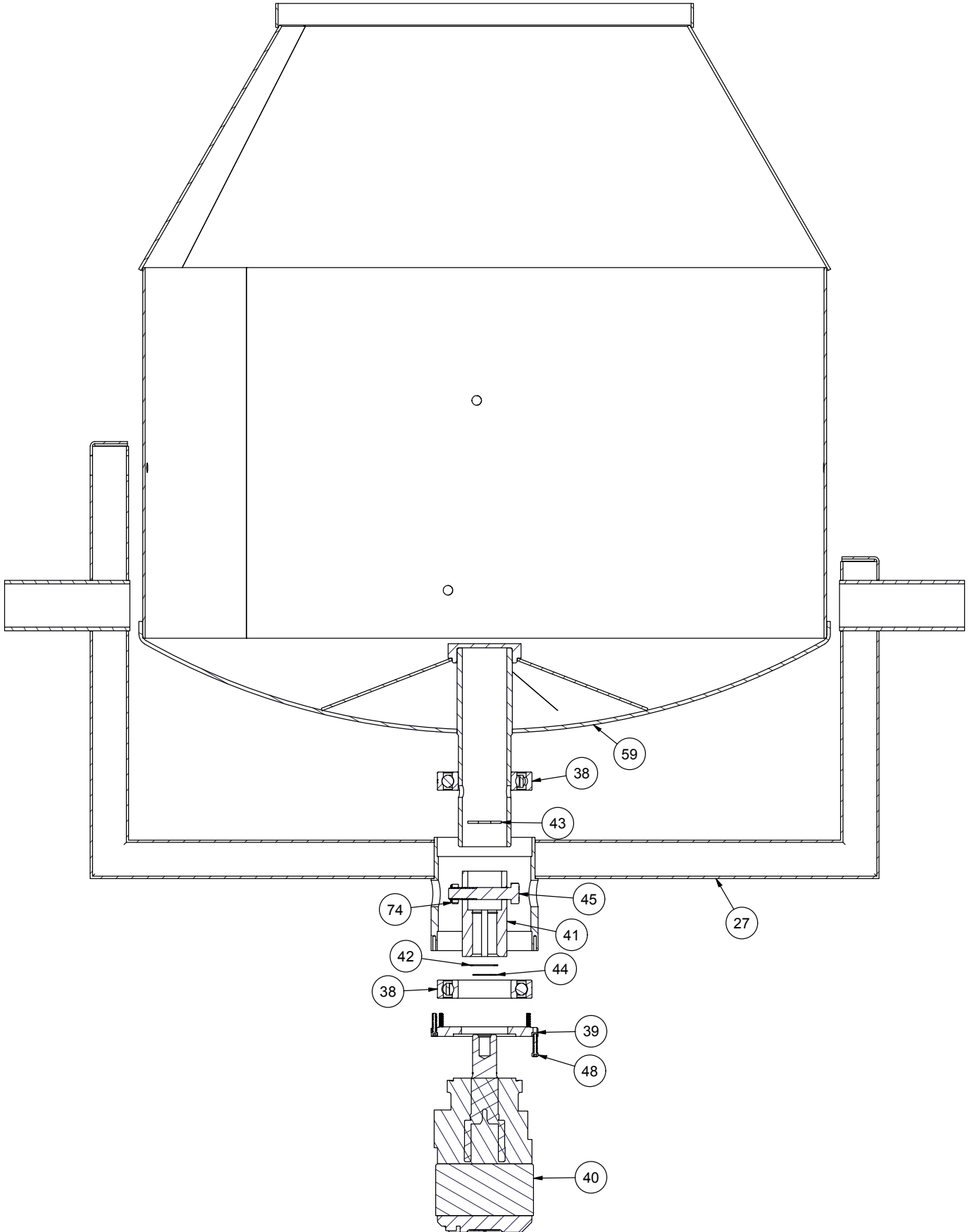

900CM DRUM SHAFT PARTS BREAKDOWN:

REF #	NAME	PART #	QTY
40	MOTOR, HYD PARKER TF036OAS030AAAA	WX2662	1
48	#10-24 SHCS X 1" LONG	*	6
39	COLLAR END PLATE	WX2670	1
38	BEARING, RADIAL, 70MM ID, 125MM OD	WX2664	2
44	WASHER, 1.235" OD .628" ID, .05 THICK	WR1435	1
42	SNAP RING, 1.25" SHAFT, .05 THICK	*	1
41	DRUM DRIVE SHAFT COUPLER	WX2665	1
74	NUT, 5/8-1 THIN NYLOCK	*	1
45	HCS 5/8-11 X 3.25 LONG GRADE 8	*	1
27	YOKE WELDMENT	R0395	1
43	WASHER, 1.75 OD 1.629 ID .119 THICK	WR1434	1
59	DRUM WELDMENT	R0394	1

* Common hardware, can be purchased locally.

YOKE ASSEMBLY EDI# 21237 INCLUDES:

REF #	NAME	QTY
3	YOKE ASSEMBLY	1

STEEL DRUM ONLY EDI# 21239 INCLUDES:

REF #	NAME	QTY
15	STEEL DRUM ASSEMBLY	1

AXLE AND ENGINE ASSEMBLY

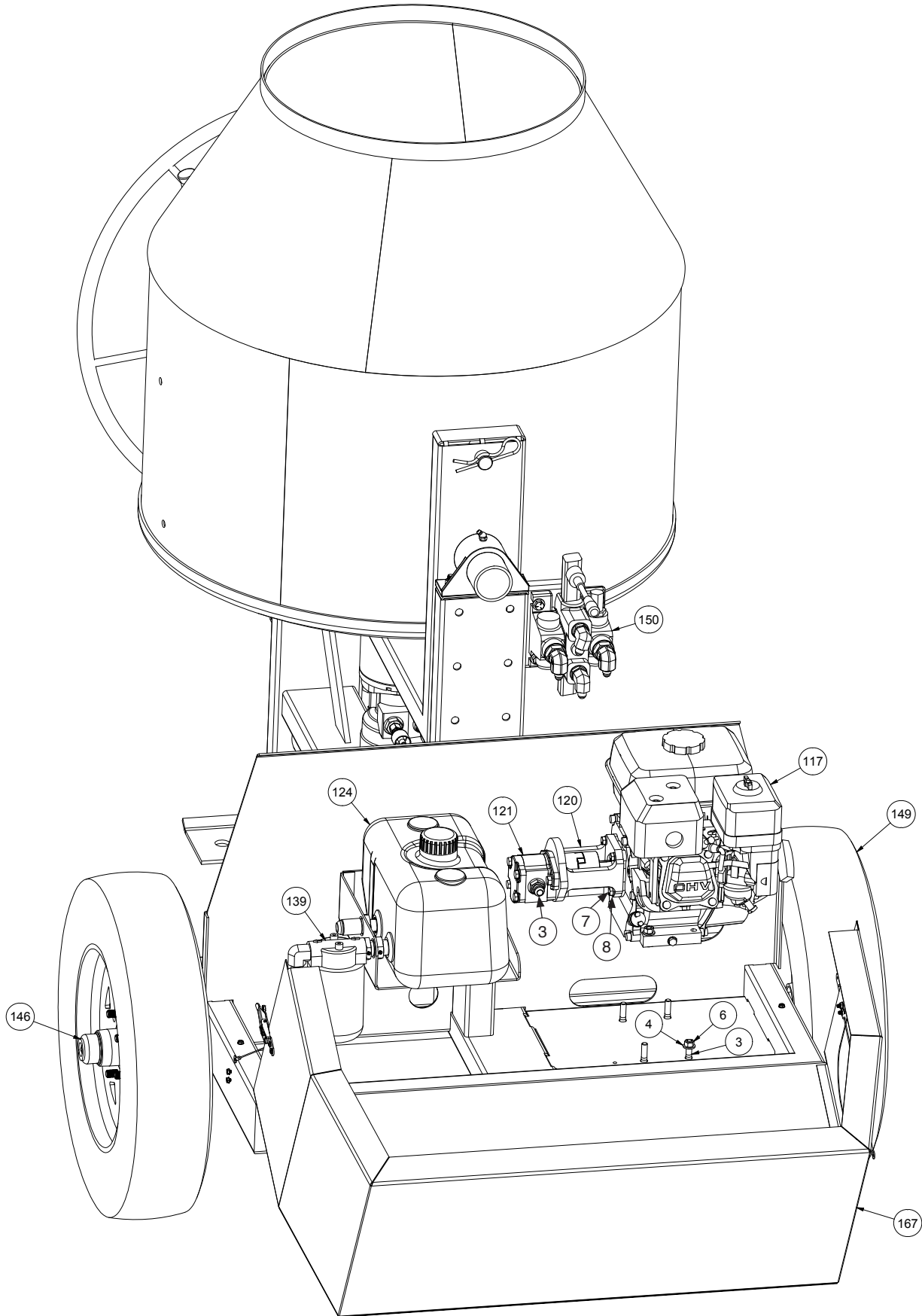

AXLE AND ENGINE TABLE PARTS BREAKDOWN

REF #	NAME	PART#	QTY
146	SOLID AXLE ASSEMBLY	WX2271	1
139	FILTER, 10 MIC RETURN MPS50-R	WX1793	1
124	HYD TANK, POLYMER, 2.5 GALLON	WL700	1
121	PUMP, HYD PARKER PGP505A0020CA2H1ND3D2B1B1	WX2661	1
120	HAYES COUPLING G11-106-L-095-01	WX2663	1
117	ENGINE, HONDA GX200	WX2697	1
150	HYDRAULIC VALVE SET	WX2162	1
149	WHEEL AND TIRE ASSM	WX2080	1
3	HCS 3/8"-16NC X 1.5 LONG	*	6
4	WASHER, 3/8"	*	10
6	NUT, 3/8-16	*	4
7	SHCS M8 x 25MM LONG	*	4
8	FLAT WASHER, 5/16"	*	4
167	ENGINE HOUSE	RO396	1
NS	HYDRAULIC HOSE KIT	WX2696	1

* Common hardware, can be purchased locally.

LUG NUT KIT EDI# 27819 INCLUDES:

REF #	NAME	QTY
7	OPEN WHEEL NUT	10

WHEEL & TIRE EDI# 27906 INCLUDES:

REF #	NAME	QTY
8	WHEEL & TIRE	1

ENGINE

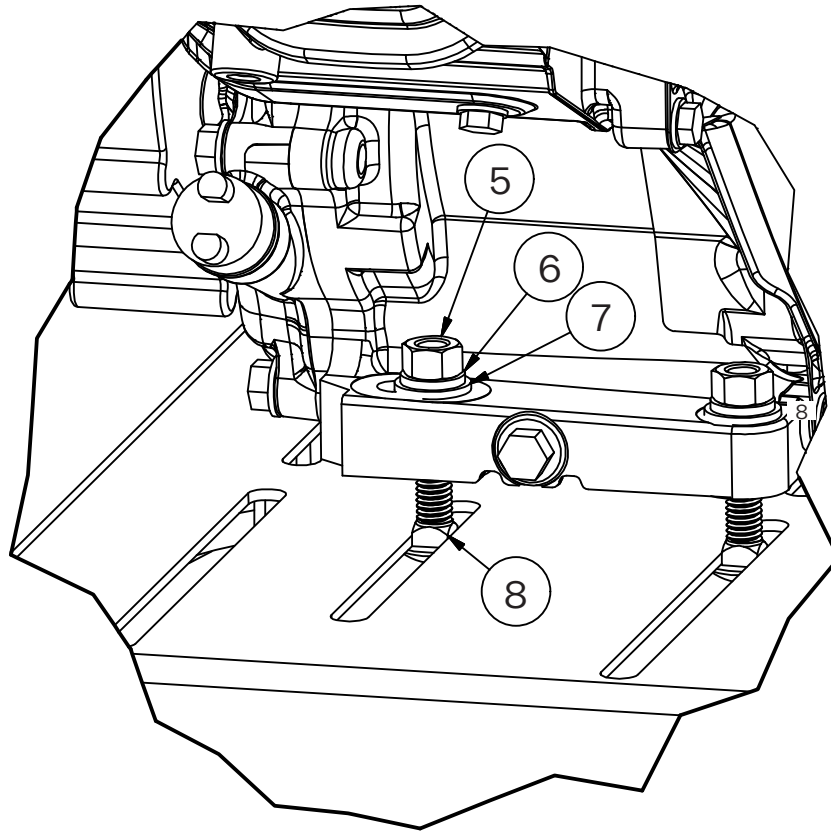

ENGINE, GX200 HONDA FOR 900CM

REF #	NAME	QTY
1	ENGINE, GX200OUT2 - QX2	1

900CM GAS ENGINE INSTALL HDW EDI# 27816 INCLUDES:

REF #	NAME	QTY
5	HEX NUT, 3/8"-16	4
6	LOCK WASHER, 3/8"	4
7	FLAT WASHER, 3/8"	4
8	CARRIAGE BOLT, 3/8"-16 X 1 3/4"	4



104 S. 8th Ave., Marshalltown, IA
Phone 800-888-0127 / 641-753-0127
Fax 800-477-6341 / 641-753-6341
www.MARSHALLTOWN.com
WS2173