

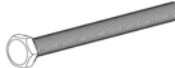







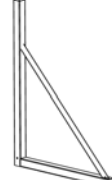

MRWH

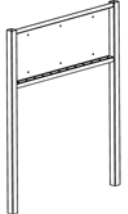
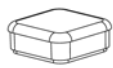
Rolling Stand With 12 Pivot Hangers Assembly Instructions

PARTS LIST

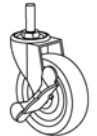
Part	Description	Qty
1	 Non-locking caster assembly	2
2	 M4X60 bolt	2
3	 Washer	2
4	 Spreader assembly	1
5	 Side frame assembly	2
6	 M6X8 set screw	4
7	 Upper frame assembly	1
8	 Tube caps	2
9	 Spring	12
10	 Hanger	12
11	 Lower frame assembly	1
12	 Locking caster assembly	2
13	 Allen key	1

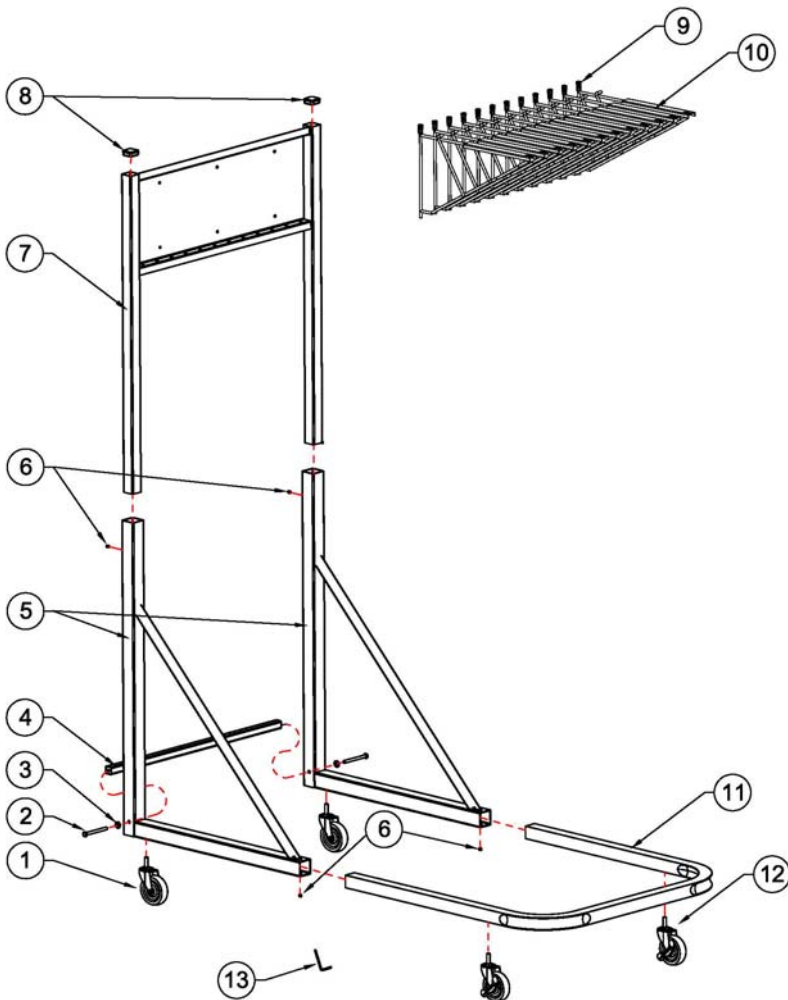

MRWH

Rolling Stand With 12 Pivot Hangers

Assembly Instructions

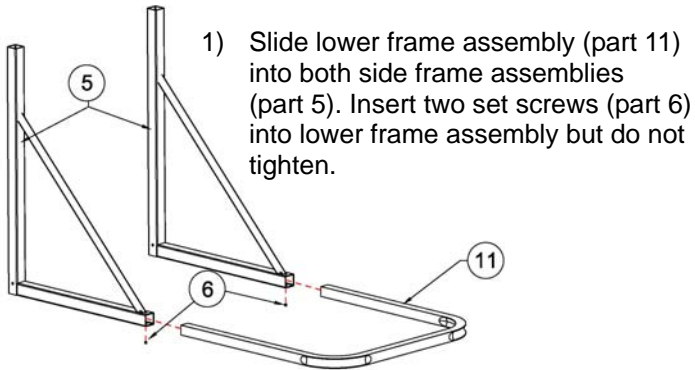

- 2) Attach spreader assembly (part 4) into side frame assembly using two M4X60 bolts (part 2) and washers (part 3).

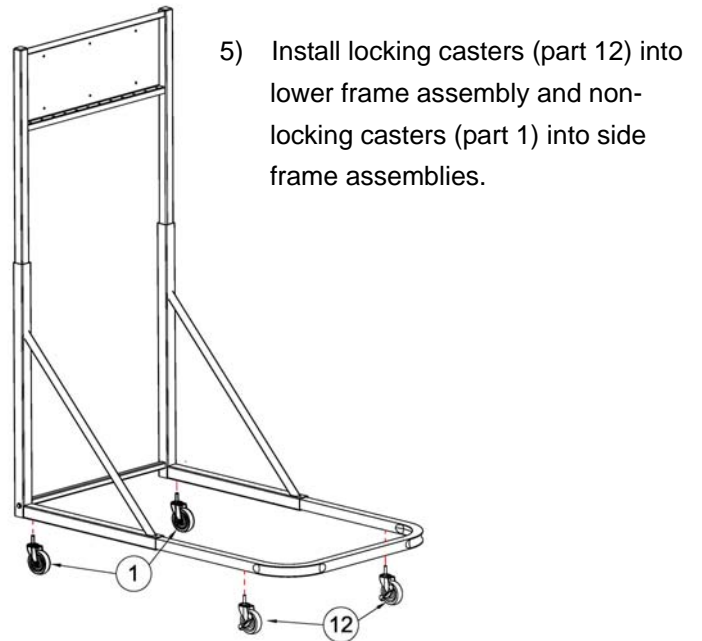
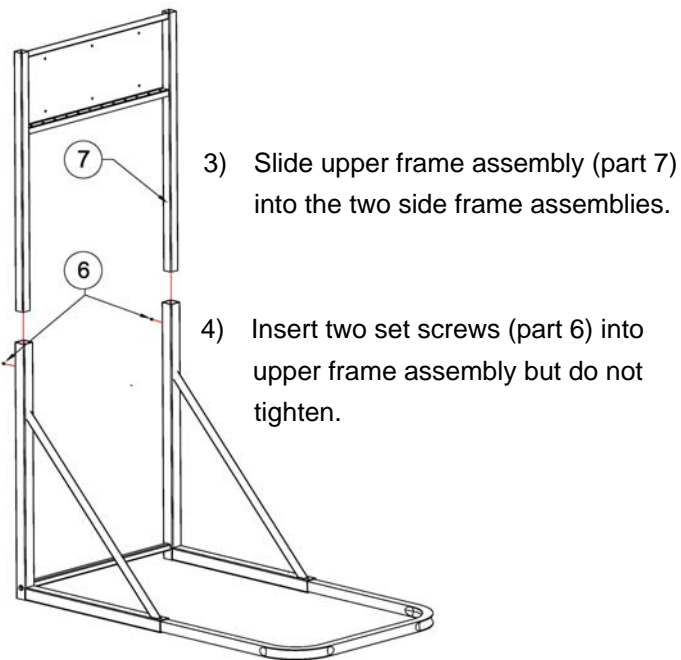
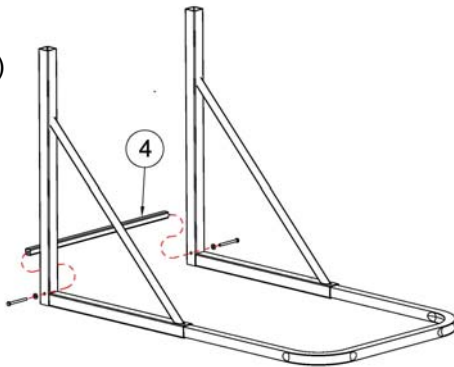

- 6) Guide 12 hangers (part 10) with 12 springs (part 9) at top of hangers into the top of the upper frame assembly as shown in diagram and then insert lower part of hanger into bottom hole of upper frame assembly.

