

Mobile Plan Center

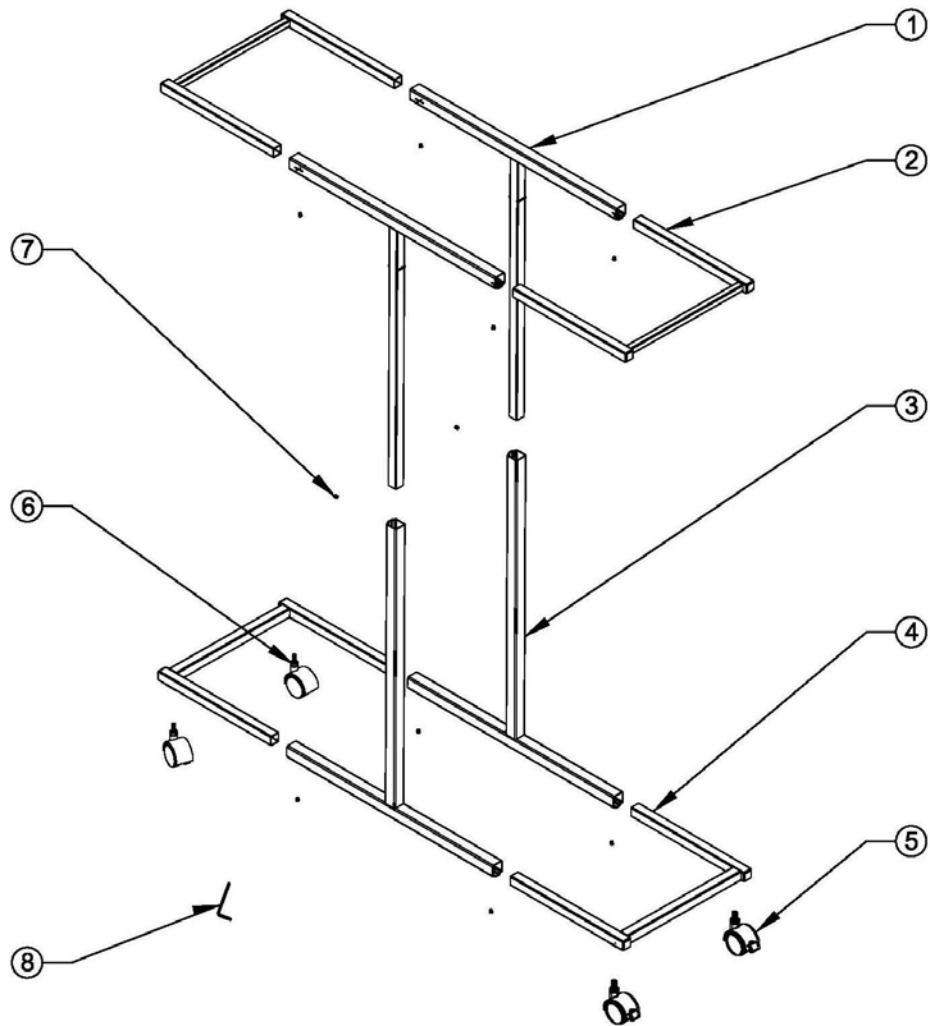

Item	Description	Qty
1	Upper tube assembly	2
2	Upper end tube assembly	2
3	Lower tube assembly	2
4	Lower end tube assembly	2
5	Locking caster	2
6	Non-locking caster	2
7	M6X8 set screw	10
8	Allen key	1

- 1) Insert upper tube assembly(1)into lower tube assembly(3)
 [Tube of upper tube assembly (1) is smaller than lower tube assembly (3)] .
- 2) Insert lower end tube assembly (4)into lower tube assembly (3)
 [Tube of lower end tube assembly (4) is bigger than upper end tube assembly (2)]
- 3) Insert upper end tube assembly (2)into upper tube assembly(1)
- 4) Install locking casters (5)and non-locking casters(6)into lower end tube assembly (4)
- 5) Install set screws (7)into upper(1)and lower(3)tube assemblies and adjust for height and depth.